

# Coprocessor Modules

IC697PCM711

GFK-0164G  
August 1997

## Programmable Coprocessor Module

### Features

- Single slot Coprocessor
- Dual Tasking
- MegaBasic™
- CCM2 Protocol
- 12 Mhz, 80C186 microprocessor
- 90% of an IBM® AT performance
- Up to 96 Kbytes battery-backed CMOS logic and data memory on board
- Supports up to 512 Kbytes optional expansion memory
- Programmed by IC647, IC640 or IBM-compatible Personal Computer
- Two RS-422/RS-485 or RS-232 serial ports
- High performance access to PLC memory
- Real time calendar clock synchronized to PLC
- Reset pushbutton
- Three Status LEDs
- Soft Configuration (No dip switches or jumpers) with MS-DOS® or Windows® based programming software configuration function
- Simultaneous communications on both ports at up to 9.6 Kbaud, or up to 19.2 Kbaud individually.

### Functions

The Programmable Coprocessor Module (PCM) is a Coprocessor to the PLC CPU. It can be programmed to perform operator interface, real time computations, data storage, data acquisition and data communications functions. It communicates with the PLC CPU over the backplane and can access user and system data using extensions to the powerful MegaBasic language. No application program support is required in the PLC CPU.

Many PCMs can be supported in a single IC697 PLC system and each can accommodate an optional expansion memory up to 512 Kbytes.

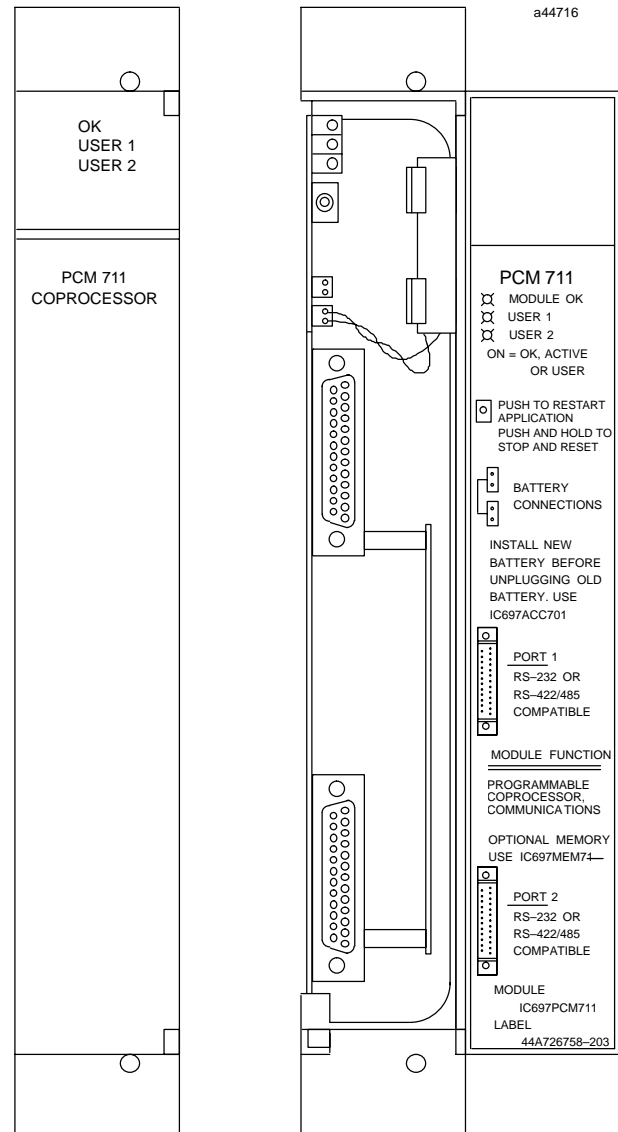

Dual tasking allows running a MegaBasic program at the same time the PCM is used as a communications interface. Operation of the module may be initialized by a pushbutton or by an attached PCM development system. The status of the PCM is indicated by three green LEDs on the front of the module.

™ MegaBasic is a trademark of Christopher Cochran; ©IBM is a registered trademark of International Business Machines Corporation.

© MS-DOS and Windows are registered trademarks of Microsoft Corporation.

GFK-0164G  
August 1997

Programmable Coprocessor Module

Installation

- Installation should not be attempted without referring to the applicable *Programmable Controller Installation Manual* (see reference 5).
- Make sure rack power is off.
- Install expansion memory if required.
- Connect the battery to either of the battery connectors on the module. (See figure 2)
- Install in the rack. (See figure 1)
- Turn on power.

The module should power up and blink the top LED. When the diagnostics have completed successfully the top LED stays on.

Expansion Memory

The PCM can operate with or without an expansion memory daughter board. The base memory on the PCM board has up to 95 Kbytes user memory. The expansion memory daughter board permits expansion of program/data memory by 64, 128, 256 or 512 Kbytes. The battery which supports this memory is located on the base board housing as shown in figure 2.

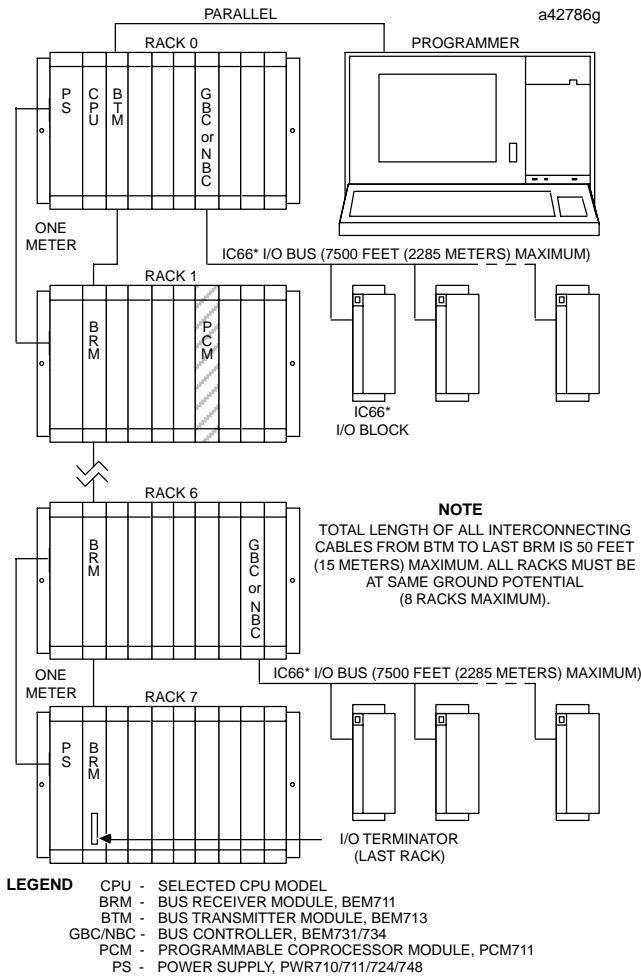

Figure 1. Typical PLC System Configuration (PCM Shown in Rack 1)

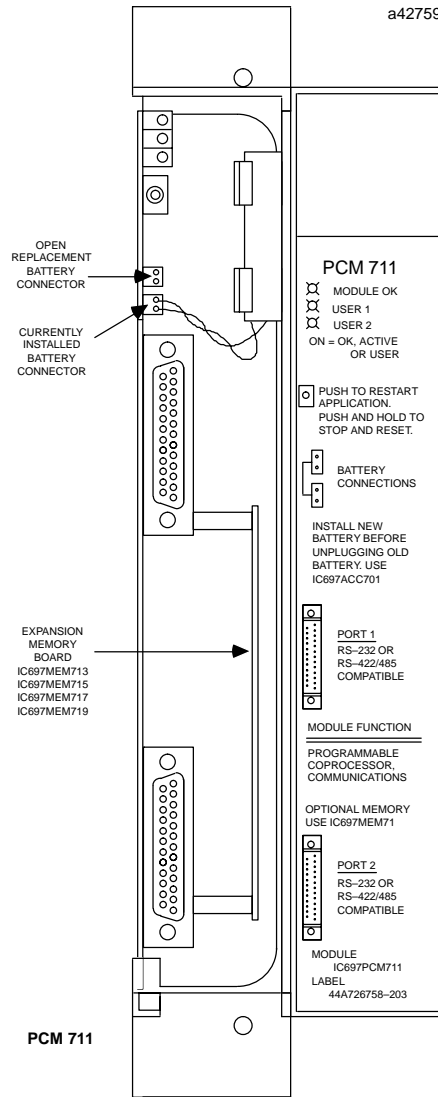

Figure 2. Programmable Coprocessor Module - User Details

**Programmable Coprocessor Module**

GFK-0164G  
August 1997

**Programming and Configuration**

An IC647 or IC640 computer, or IBM-compatible PC, XT, or AT computer with PCM Development Software installed is connected to the top port of the PCM. The default setting is 19,200 bps. The PCM Development Software is used to configure the serial port parameters, to define the interface to the PLC CPU, to select task functions and to program MegaBasic applications. The PCM parameters can also be configured using MS-DOS® or Windows® programming software. Consult reference 3 for details of operation.

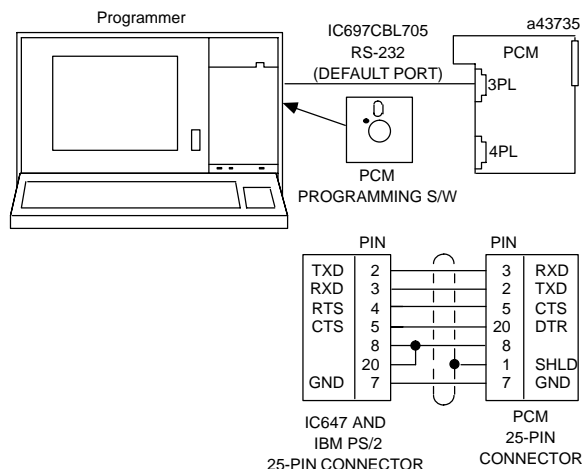

Figure 3. PCM Development System Connection to PCM

**Serial Ports**

Both ports are RS-232 and RS-422/RS-485 compatible. Both ports acting simultaneously can each support up to 9.6 Kbaud full duplex data communications, or they can support up to 19.2 Kbaud individually.

**Port 1 (3PL) and Port 2 (4PL)**

Connectors 3PL and 4PL contain signals for both RS-232 and RS-422/RS-485 types of communication circuits. The pin-out for the RS-232 signals are per the RS-232 specification with an exception that pins not normally used for RS-232 are used for RS-422/RS-485 signals. Details are shown in tables 1 and 2.

Table 1. Port 1 or 2 - RS-232

PIN	FUNCTION	SIGNAL NAME	I/O
1	Shield	-	-
2	Transmitted Data	TD	Output
3	Received Data	RD	Input
4	Request To Send	RTS	Output
5	Clear To Send	CTS	Input
7	Signal Ground	0V	-
8	Data Carrier Detect	DCD	Input
20	Data Terminal Ready	DTR	Output

Table 2. Port 1 or 2 - RS-422/RS-485

PIN	FUNCTION	SIGNAL NAME	I/O
9	Send Data (A)	SD (A)	Output
10	Request to Send (A)	RTS (A)	Output
11	Clear to Send (A)	CTS (A)	Input
12	Termination for pin 13	-	-
13	Receive Data (A)	RD (A)	Input
21	Send Data (B)	SD (B)	Output
22	Request to Send (B)	RST (B)	Output
23	Clear to Send (B)	CTS (B)	Input
24	Termination for pin 23	-	-
25	Receive Data (B)	RD (B)	Input

**Configuration**

There are no user DIP switches or jumpers on this board for configuration. However, the board must be configured before operation using PCM Development Software (See reference 3).

**Status Indication**

Three Status LEDs are available as shown in Figure 2. The top LED indicates the condition of the module, the bottom two LEDs may be assigned to a configured function.

**Controls**

One pushbutton is provided. Push and hold for less than 5 seconds will restart an application. Push and hold for more than 5 seconds and the module factory default configuration will be installed (this action will not clear memory but will permit communication with the programmer using factory default settings).

GFK-0164G  
August 1997

## Programmable Coprocessor Module

### Batteries

A lithium battery (IC697ACC701) is installed as shown in figure 2. This battery maintains user memory when power is removed. Be sure to install the new battery before removing the old battery.

If during power-up diagnostics a low battery is detected the Module OK LED (top) will not stay on. Specific indication of a low battery state is detailed in the *PCM Support Software User's Manual*.

Table 3. References

Reference	Title
1	ProgramingSoftware User 's Manual
2	ProgrammableControllerReference Manual
3	PCM Support Software User 's Manual
4	MegaBasicProgramming Language Reference Manual
5	ProgrammableControllerInstallationManual

Table 4. Specifications for IC697PCM711 †

<b>Battery</b>	
Shelf life	10 years at 20°C (68°F)
Memory retention	6 months nominal without applied power.
<b>Current required from 5V bus</b>	1.0 amp
<b>Serial Ports</b>	RS-232/RS-422/RS-485 compatible
<b>VME</b>	System designed to support the VME standard C.1

† Refer to GFK-0867B, or later for product standards and general specifications. If the PLC installation must comply with supported standards, such as FCC or CE Directives, please refer to the *Installation Requirements for Conformance to Standards*, shipped with the PLC programming software, for additional guidelines.

Table 5. Ordering Information

Description	Catalog Number
PCM, 12 Mhz, 20 Kbyte, Expandable	IC697PCM711
64 Kbyte CMOS Expansion Memory	IC697MEM713
128 Kbyte CMOS Expansion Memory	IC697MEM715
256 Kbyte CMOS Expansion Memory	IC697MEM717
512 Kbyte CMOS Expansion Memory	IC697MEM719
Lithium Battery	IC697ACC701

Note: For Conformal Coat option, or Low Temperature Testing option please consult the factory for price and availability.