



10216/2/1

Fail-safe loop-monitored digital output module (24 Vdc, 1 A, 4 channels)

Description

The fail-safe digital output module 10216/2/1 has four 24 Vdc, 1 A loop-monitored output channels to drive loads up to 24 W. The maximum module load is 3.6 A.

These loads may be resistive or inductive. For inductive loads, a suppression diode is included on each output.

The outputs, including the suppression diode, the lead breakage detection and short-circuit detection, are fully tested and may therefore be used for fail-safe applications.

The outputs are tested for:

- ability to de-energize,
- ability to de-energize via the secondary means,
- crosstalk between outputs,
- function of the suppression diodes,
- lead breakage in the (external) output wiring, and
- short circuit of the outputs.

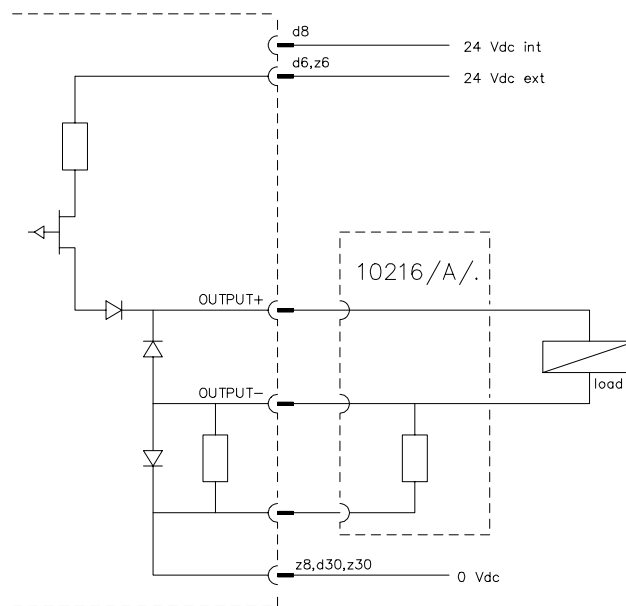

Figure 1 Schematic diagram for connection of one output to the 10216/2/1 module



The outputs have a secondary means of de-energization, which enables the watchdog and/or the processor to de-energize the outputs irrespective of the result of the application function.

Note:

The 10216/2/1 module can only be used in combination with an I/O backplane in the rack, since the outputs require a 10216/A/. module.

Loop-monitoring

All outputs are monitored for lead breakage and short circuit. To get a rough lead breakage current setting, the current sense level must be programmed (see Table 1 below).

Table 1 Selection of range-setting module

LOAD		Range-setting module
Spare channel		10216/A/1
0.1 - 0.39 W	4 - 16 mA	none
0.4 - 1.1 W	17 - 47 mA	10216/A/2
1.2 - 4.7 W	48 - 199 mA	10216/A/3
≥ 4.8 W	≥ 200 mA	10216/A/4

Pin allocation

The back view and pin allocation of the 10216/2/1 module connector are as follows:

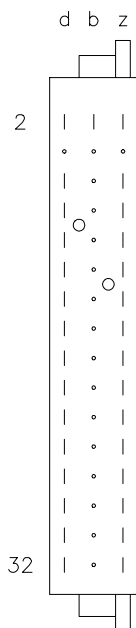

d2	WDG	b2	GND	z2	VCC
d4	–			z4	–
d6	Supply 24 Vdc ext.			z6	Supply 24 Vdc ext.
d8	Supply 24 Vdc int.			z8	Supply 0 Vdc
d10				z10	
d12	(0 Vdc)			z12	(0 Vdc)
d14	OUT 1+			z14	OUT 1–
d16	0 Vdc			z16	0 Vdc
d18	OUT 2+			z18	OUT 2–
d20	0 Vdc			z20	0 Vdc
d22	OUT 3+			z22	OUT 3–
d24	0 Vdc			z24	0 Vdc
d26	OUT 4+			z26	OUT 4–
d28	0 Vdc			z28	0 Vdc
d30	Supply 0 Vdc			z30	Supply 0 Vdc
d32				z32	



Connection example

The figure below shows a connection example for the fail-safe digital output module 10216/2/1.

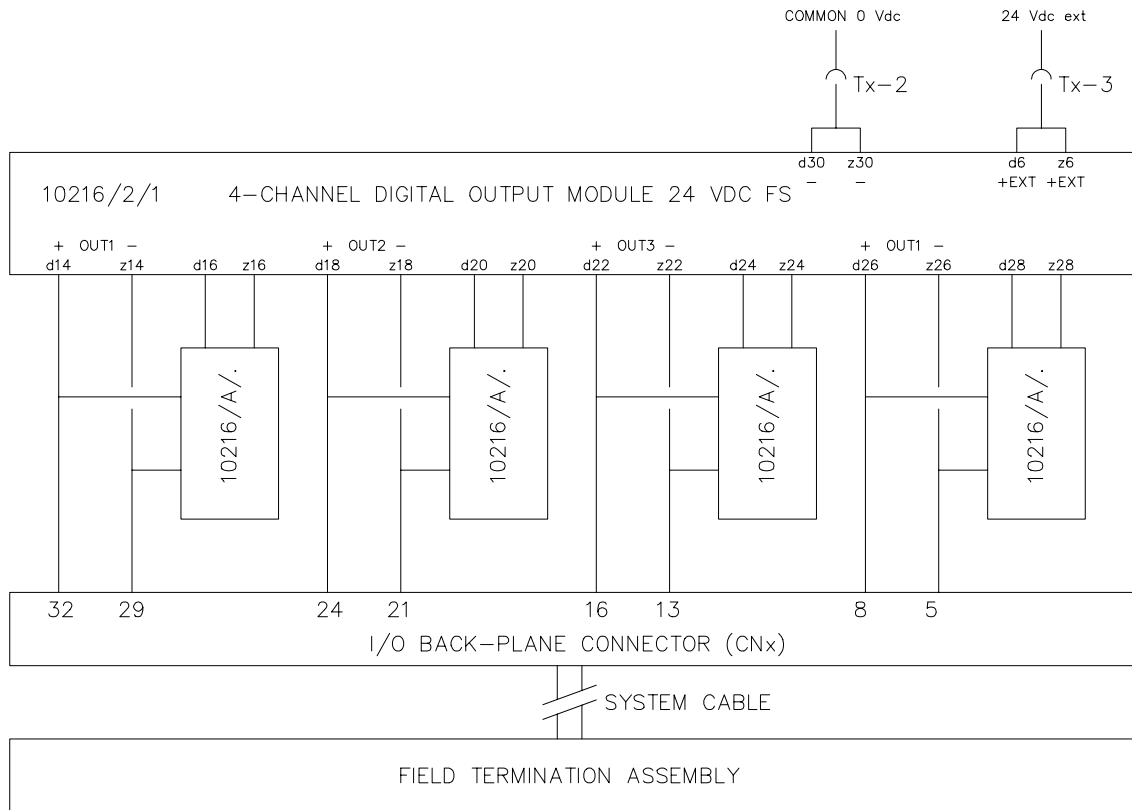

Figure 2 Connection example of 10216/2/1 module to FTA for both non-redundant and redundant I/O configurations

Note:

The 24 Vdc internal power supply (d8 and z8) must be connected to prevent fault detection during the self-test of the output module. The external power supply (d6/z6 and d30/z30), as well as dummy loads on all spare channels, must be connected to prevent fault detection during the lead breakage test of the output module.



Technical data

The 10216/2/1 module has the following specifications:

General	Type number:	10216/2/1 12400
	Approvals:	CE, TÜV, UL
	Software versions	≥ 3.00
	Space requirements:	4 TE, 3 HE (= 4 HP, 3U)
Power	Power requirements:	5 Vdc 15 mA 24 Vdc internal 50 mA 24 Vdc external 15 mA (without output load)
	Output	Number of output channels: 4
	Output specification:	24 Vdc solid-state source, short circuit proof
	Maximum channel current:	1 A (see 'FSC output modules' data sheet)
	Maximum total module load:	3.6 A (module dissipation limit)
	Maximum load inductance:	0.5 H
	Maximum load capacity:	1 µF
	Top of overload detection:	> 10 Ohm
	Cold resistance lamp:	> 20 Ohm
	Voltage drop:	< 1.3 V at 1 A
	Off current:	< 0.1 mA
	Current sense voltage drop:	< 1 V at 1 A
	WDG input current:	4 mA
Key coding	(See 'Key coding' data sheet)	
	Module code:	
	– holes	A13, C9
	Rack code:	
	– large pins	A13, C9

While this information is presented in good faith and believed to be accurate, Honeywell Safety Management Systems B.V. disclaims the implied warranties of merchantability and fitness for a particular purpose and makes no express warranties except as may be stated in its written agreement with and for its customer. In no event is Honeywell Safety Management Systems B.V. liable to anyone for any indirect, special or consequential damages. The information and specifications in this document are subject to change without notice.



10216/2/3

Fail-safe loop-monitored digital output module (48 Vdc, 0.5 A, 4 channels)

Description

The fail-safe digital output module 10216/2/3 has four 48 Vdc, 0.5 A loop-monitored output channels to drive loads up to 24 W. These loads may be resistive or inductive. For inductive loads, a suppression diode is included on each output. The outputs, including the suppression diode, the lead breakage detection and short-circuit detection, are fully tested and may therefore be used for fail-safe applications.

The outputs are tested for:

- ability to de-energize,
- ability to de-energize via the secondary means,
- crosstalk between outputs,
- function of the suppression diodes,
- lead breakage in the (external) output wiring, and
- short circuit of the outputs.

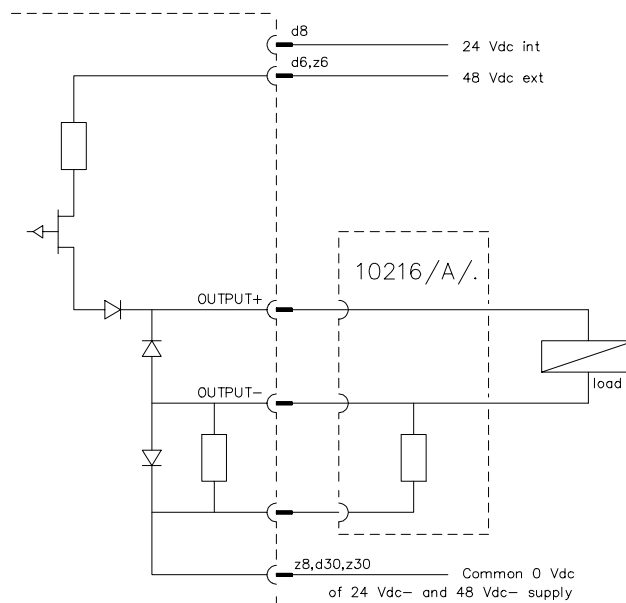

Figure 1 Schematic diagram for connection of one output to the 10216/2/3 module

The outputs have a secondary means of de-energization, which enables the watchdog and/or the processor to de-energize the outputs irrespective of the result of the application function.

Notes:

The 10216/2/3 module can only be used in combination with an I/O backplane in the rack, since the outputs require a 10216/A/ module.

The 24 Vdc (internal) and the 48 Vdc (external) must have a common 0 Vdc connection.

Loop-monitoring

All outputs are monitored for lead breakage and short circuit. To get a rough lead breakage current setting, the current sense level must be programmed (see Table 1 below).

Table 1 Selection of range-setting module

LOAD		Range-setting module
Spare channel		10216/A/1
0.1 - 0.79 W	4 - 16 mA	none
0.8 - 2.3 W	17 - 47 mA	10216/A/2
2.4 - 9.5 W	48 - 199 mA	10216/A/3
≥ 9.6 W	≥ 200 mA	10216/A/4

Pin allocation

The back view and pin allocation of the 10216/2/3 module connector are as follows:

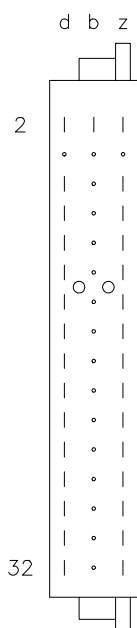

d2	WDG	b2	GND	z2	VCC
d4	–			z4	–
d6	Supply 48 Vdc ext.			z6	Supply 48 Vdc ext.
d8	Supply 24 Vdc int.			z8	Supply 0 Vdc
d10				z10	
d12	(0 Vdc)			z12	(0 Vdc)
d14	OUT 1+			z14	OUT 1–
d16	0 Vdc			z16	0 Vdc
d18	OUT 2+			z18	OUT 2–
d20	0 Vdc			z20	0 Vdc
d22	OUT 3+			z22	OUT 3–
d24	0 Vdc			z24	0 Vdc
d26	OUT 4+			z26	OUT 4–
d28	0 Vdc			z28	0 Vdc
d30	Supply 0 Vdc			z30	Supply 0 Vdc
d32				z32	



Connection example

The figure below shows a connection example for the fail-safe digital output module 10216/2/3.

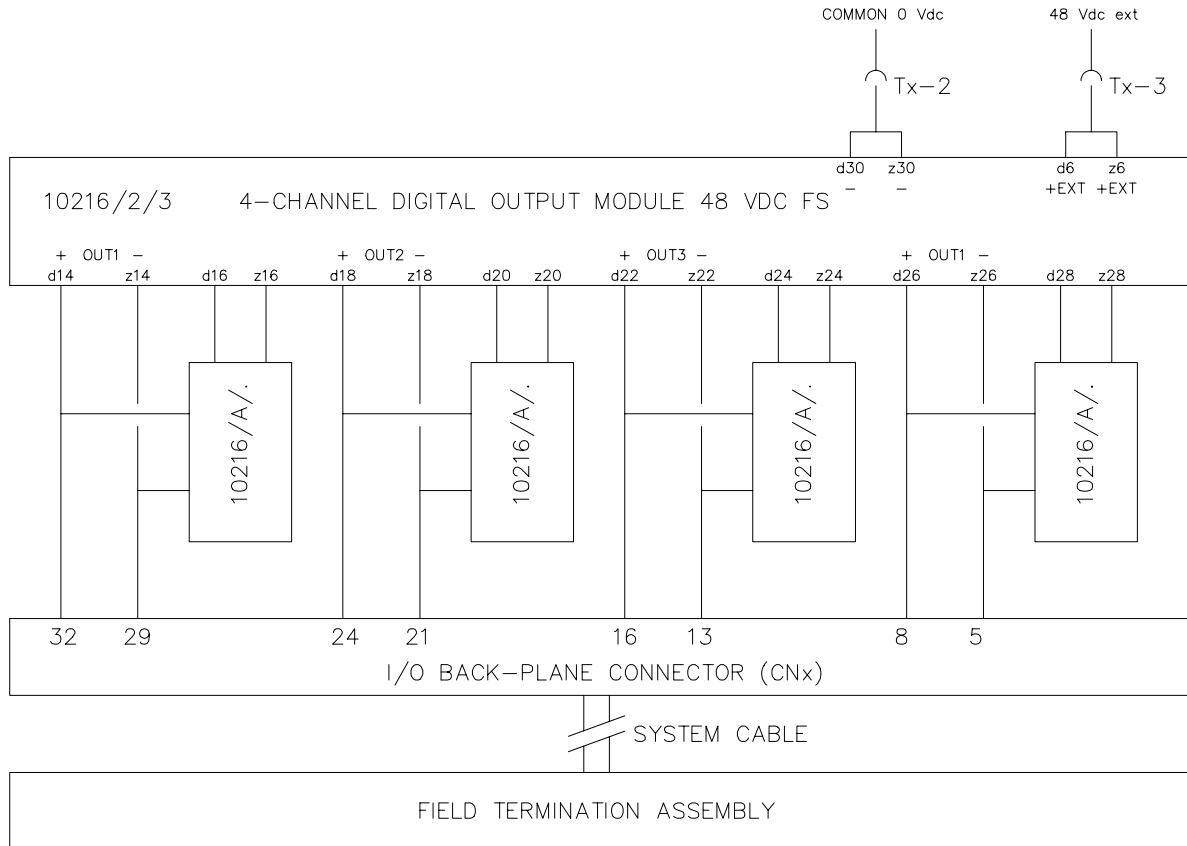

Figure 2 Connection example of 10216/2/3 module to FTA for both non-redundant and redundant I/O configurations

Note:

The 24 Vdc internal power supply (d8 and z8) must be connected to prevent fault detection during the self-test of the output module. The 48 Vdc external power supply (d6/z6 and d30/z30), as well as dummy loads on all spare channels, must be connected to prevent fault detection during the lead breakage test of the output module.



Technical data

The 10216/2/3 module has the following specifications:

General	Type number:	10216/2/3 13400
	Approvals:	CE, TÜV, UL
	Software versions:	≥ 310
	Space requirements:	4 TE, 3 HE (= 4 HP, 3U)
Power	Power requirements:	5 Vdc 15 mA 24 Vdc internal 50 mA 48 Vdc external 15 mA (without output load)
	Output	Number of output channels: 4
	Output specification:	48 Vdc solid-state source, short circuit proof
	Maximum channel current:	0.5 A (see 'FSC output modules' data sheet)
	Maximum load inductance:	1 H
	Maximum load capacity:	1 µF
	Top of overload detection:	> 40 Ohm
	Cold resistance lamp:	> 80 Ohm
	Voltage drop:	< 1.2 V at 0.5 A
	Off current:	< 0.1 mA
	Current sense voltage drop:	< 1 V at 0.5 A
	WDG input current:	4 mA
Key coding	(See 'Key coding' data sheet)	
	Module code:	
	– holes	A13, C13
	Rack code:	
	– large pins	A13, C13

While this information is presented in good faith and believed to be accurate, Honeywell Safety Management Systems B.V. disclaims the implied warranties of merchantability and fitness for a particular purpose and makes no express warranties except as may be stated in its written agreement with and for its customer. In no event is Honeywell Safety Management Systems B.V. liable to anyone for any indirect, special or consequential damages. The information and specifications in this document are subject to change without notice.



10216/A/. Range-setting modules

Description

The loop-monitored output channels of the 10216/2/. module usually need a range-setting module to put the current sense level in the proper range or to prevent lead breakage detection on spare channels. The 10216/A/. modules are placed on a programming connector (Px) on the back of the I/O backplane in the 19-inch rack. To assist proper placement of these 10216/A/. modules, a 10216 positioning print can be placed on the programming connector.

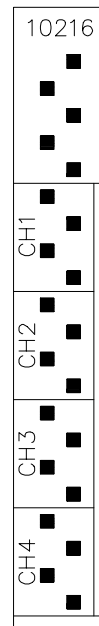

Figure 1 10216 positioning print

The printed circuit board of a 10216/A/. module should be oriented to slide into the cut-out zone of the appropriate channel. Redundant channels require only one 10216/A/. module.

10216/A/1

Spare channel

Description

The 10216/A/1 range-setting module is used for spare channels of 10216/2/. modules to prevent lead breakage detection on those channels.

The 10216/A/1 module has a 4.7 kOhm (dummy load) resistor.

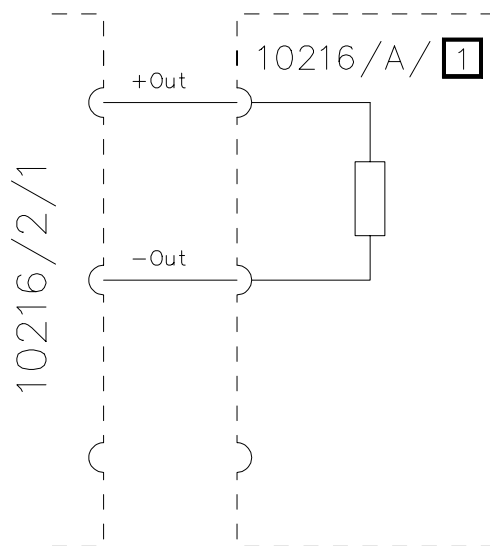

Figure 2 Schematic diagram of a 10216/A/1 module

Technical data

The 10216/A/1 module has the following specifications:

General

Type number:	10216/A/1
Approvals:	CE, TÜV, UL
Number of channels:	1
Dimensions:	23 x 10.2 x 9 mm (0.91 x 0.4 x 0.35 in)
Rack space requirements:	none (placed on programming connector on I/O backplane)

Power

Power requirements:	5 mA from 24 Vext. of 10216/2/1 10 mA from 48 Vext. of 10216/2/3
---------------------	---